

BlueLink™ 6.0 single-chip Bluetooth® and FM solution



Key benefits:

- Industry's best-performing *Bluetooth* specification 2.0 + EDR and highest fidelity FM stereo and mono performance on a single chip
- Integration of *Bluetooth* and FM in the same silicon provides 25 percent solution size savings compared to discrete solution
- Proven *Bluetooth*-FM RF co-existence
- Complete software stack support for *Bluetooth* and FM, enabling ease of design and quick time-to-market
- On-chip power management adapted to cellular applications
- Incorporates TI's *Bluetooth* and WLAN co-existence hardware and software solution, providing a collaborative interface with TI's mobile WLAN chipsets
- Uses TI's DRP™ technology and is manufactured using 90-nm CMOS to deliver smallest and lowest cost *Bluetooth* and FM single-chip solution

P R O D U C T B U L L E T I N

Overview

Optimized for mobile terminals, the BRF6350 is the newest addition to Texas Instruments (TI's) BlueLink™ 6.0 family of products for *Bluetooth*® wireless networking. As TI's fourth generation *Bluetooth* single-chip, the BRF6350 is a digital CMOS solution that integrates a complete *Bluetooth* Specification v2.0+EDR system with an FM radio receiver on a single piece of silicon.

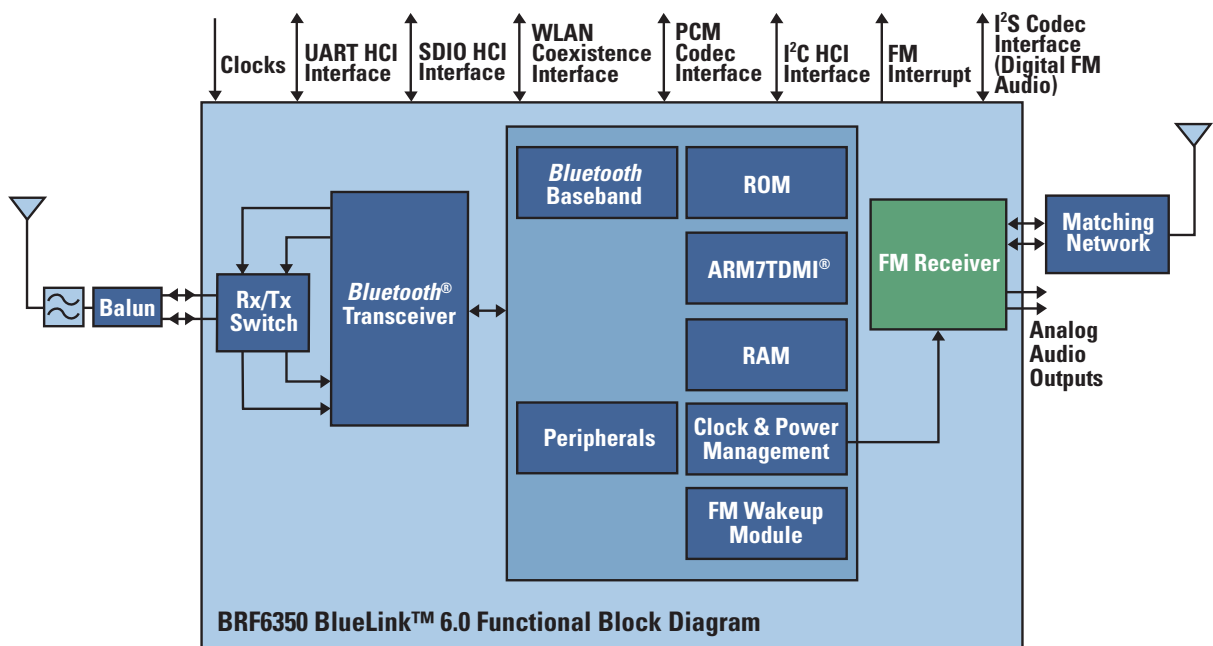

TI's BRF6350 is a highly integrated device, including *Bluetooth* baseband, RF transceiver, ARM7TDMI[®], memory (ROM and RAM), power management and an FM receiver. The BRF6350 utilizes TI's 90 nm manufacturing capabilities and DRP[™] technology, a revolution in RF technology offering major advantages over the existing solutions based on analog RF to reduce size, power and cost of wireless semiconductors.

General features

- Highly optimized for mobile terminals
 - Supports major cellular reference frequencies
 - Only 13 external components total for both FM and *Bluetooth* functions
 - Small PCB layout area: 45 mm²
 - McBSP compatible I/F
 - Low power consumption
- Flexibility to be easily integrated into various host system topologies:
 - The *Bluetooth* and FM interfaces could be separated from each other (e.g. separate host interface, separate digital audio)
 - The *Bluetooth* and FM interfaces could be shared (e.g. same host interface, same digital audio)
- The two functions can work simultaneously
 - FM receives/scans/sends RDS information to host, while *Bluetooth* can be in any operational mode
- Small package
 - 3.88 x 3.52 x 0.62 Wafer Scale Package (WSP)
- On-chip power management adapted to cellular applications
 - LDO support range: 1.7 V to 1.9 V
 - Direct connection to battery: 2.2 V to 5.4 V
 - Feeding from DC2DC
 - Power saving modes to minimize power consumption when *Bluetooth* and FM functions are not in use
- Temperature detection and compensation mechanism ensures minimal variation in the RF performance over the whole temperature range
- Complete reference designs with TI's TCS cellular chipsets and OMAP[™] applications processors for fast time-to-market
- Fully embedded FM receiver (including synthesizer and VOC tank)

FM features

- Supports US/Europe and Japanese FM bands
- Fully embedded RDS/RBDS demodulation
- Reliable stereo indication
- Digital receiver architecture (selectivity, image rejection, demodulation) ensuring performance robustness in extreme conditions
- Very low sensitivity level and superior interference rejection
- Frequency
 - Range: 76-108 MHz
 - Channel resolution: 50 KHz
- Supports mono/stereo modes
- Supports standard FM radio functionality
 - Autonomous scan functionality (station seek) including soft mute
 - Set frequency
 - Increase/decrease frequency by one step
 - Forward RDS data to the host
 - Receive either mono or stereo
 - Support mono/stereo blend
 - Support mute
- FM interfaces
 - Analog left/right audio outputs
 - Serial left/right digital stereo audio on I²S
 - RF_IN – Differential input to low-noise amplifier
 - I²C control bus
 - Asynchronous interrupt to the host

Bluetooth features

- Enhanced data rate: 2 Mbps and 3 Mbps
- Full *Bluetooth* Specification v2.0+EDR
- Support of SDIO 1 bit, byte basis mode
- Low power scan (page and inquiry scan < 100 μ A)
- Improved RF performance
 - Sensitivity: -85 dBm
 - TX Power: 4 dBm (typical)
- Fast UART, up to 4 Mbps for full EDR support
 - High rate H4 UART HCI
 - High rate HCI three wire UART transport layer (H5)
- Superior coexistence mechanisms
 - Collaborative interface with TI's WLAN chipsets to enable VoIPoWLAN and *Bluetooth* voice (bandwidth sharing, antenna sharing)
 - *Bluetooth* Specification v2.0 AFH

Bluetooth features (continued)

- Enhanced Codec (PCM) I/F capabilities
- TI's DRP technology provides the following benefits:
 - Support for EDR *Bluetooth* technology (DQPSK & 8PSK)
 - Integrated 2.4 GHz RF transceiver
 - All digital PLL transmitter with digitally controlled oscillator
 - Near zero IF architecture
 - TX/RX switch
 - Support for Class 1 applications
 - RF built-in-self-test (BIST)
- Automatic clock detection mechanism
- Patch trap mechanism that enables feature changes in ROM (ROM updates, improvements)

For more information

www.ti.com/bluelink_6

Important Notice: The products and services of Texas Instruments Incorporated and its subsidiaries described herein are sold subject to TI's standard terms and conditions of sale. Customers are advised to obtain the most current and complete information about TI products and services before placing orders. TI assumes no liability for applications assistance, customer's applications or product designs, software performance, or infringement of patents. The publication of information regarding any other company's products or services does not constitute TI's approval, warranty or endorsement thereof.

Technology for Innovators, the black/red banner, BlueLink, DRP and OMAP are trademarks of Texas Instruments.
The Bluetooth word mark and logos are owned by Bluetooth SIG. Inc., and any use of such marks by Texas Instruments is under license.
All other trademarks are the property of their respective owners.

A042605